



# DICAM

Università di Bologna  
*Bujumbura, 24 Fevrier 2015*



# Università de Bologna

## **Alma Mater Studiorum-University of Bologna (c)**

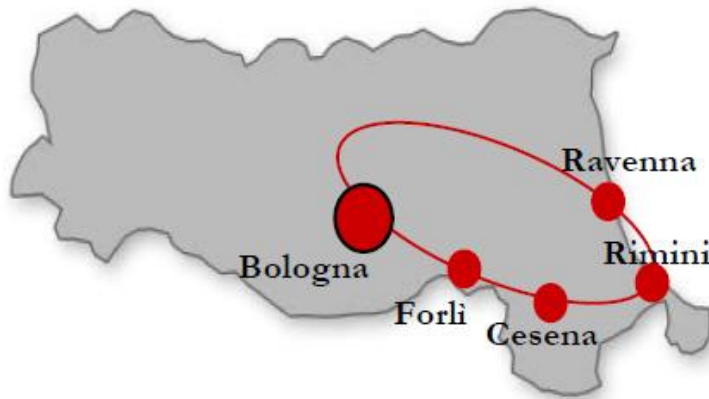

### "STATE OF THE ART" at 2008

**5 Campus**  
**Covered Area: 630.000 m<sup>2</sup>**  
**23 Faculties**  
**100 Departs. & Research Centres**

**Students: ~ 90.000**  
**Researchers & Professors: ~ 3.000**  
**Technicals&Administrative: ~ 3.000**  
**Not permanent staff: ~ 3.000**

**Total Budget: ~ 700M€/year**



# Les écoles

## **Alma Mater Studiorum-University of Bologna (d)**

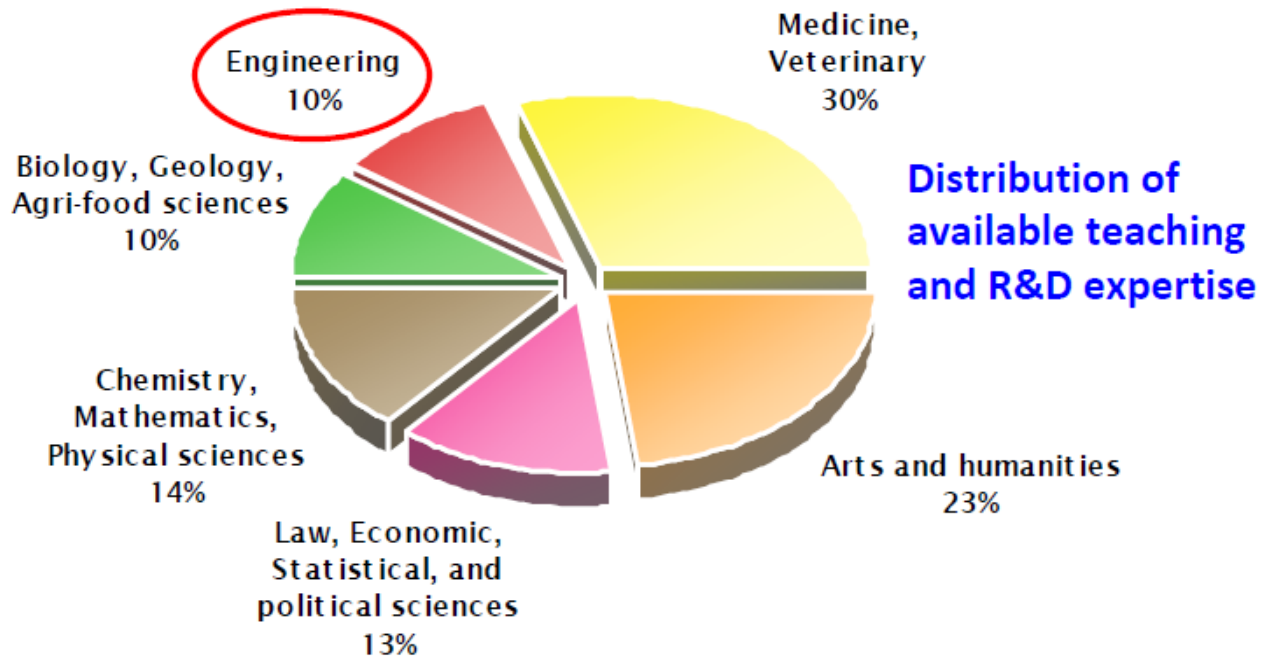



# School of Engineering



## Faculty of Engineering

(Bologna Campus, since 1937, from the previous School of Engineering of 1877 )

[www.ing.unibo.it](http://www.ing.unibo.it)

## 2nd Faculty of Engineering

(Cesena & Forlì Campus, since 2002)

[www.ing2.unibo.it](http://www.ing2.unibo.it)

## Faculty of Architecture

(Cesena/Forlì Campus, since 1999)

[www.arch.unibo.it](http://www.arch.unibo.it)

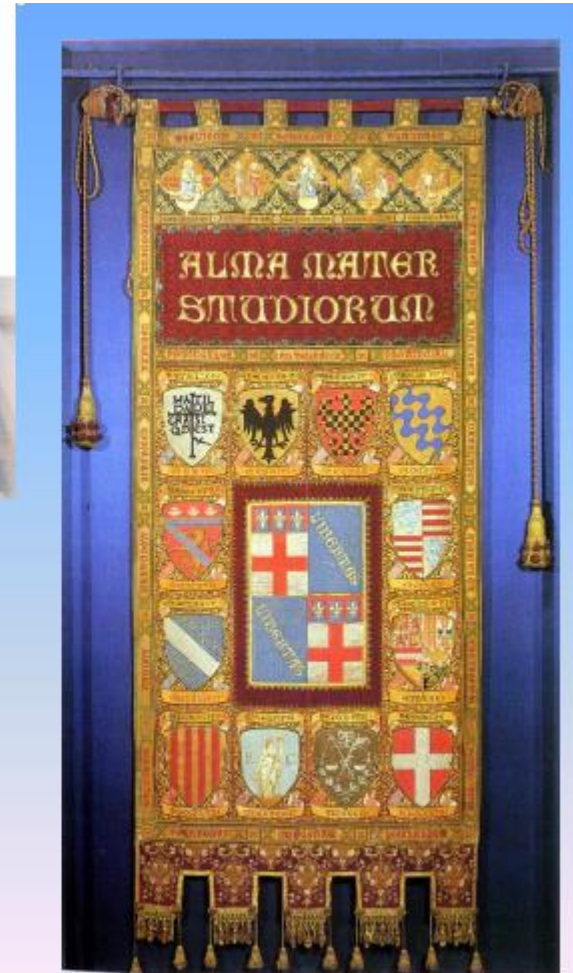



# Une longue tradition pour la construction des bâtiments





# Une longue tradition pour la construction des bâtiments





# Une longue tradition pour la construction des bâtiments





# Les batiments

- Construction **économique**
- Construction **fiable**
- Construction **durable**



# La construction

- Dessin et calcul (économique et fiable)
- Matériaux (économique et fiable)
- Construction bien fait (économique et fiable)

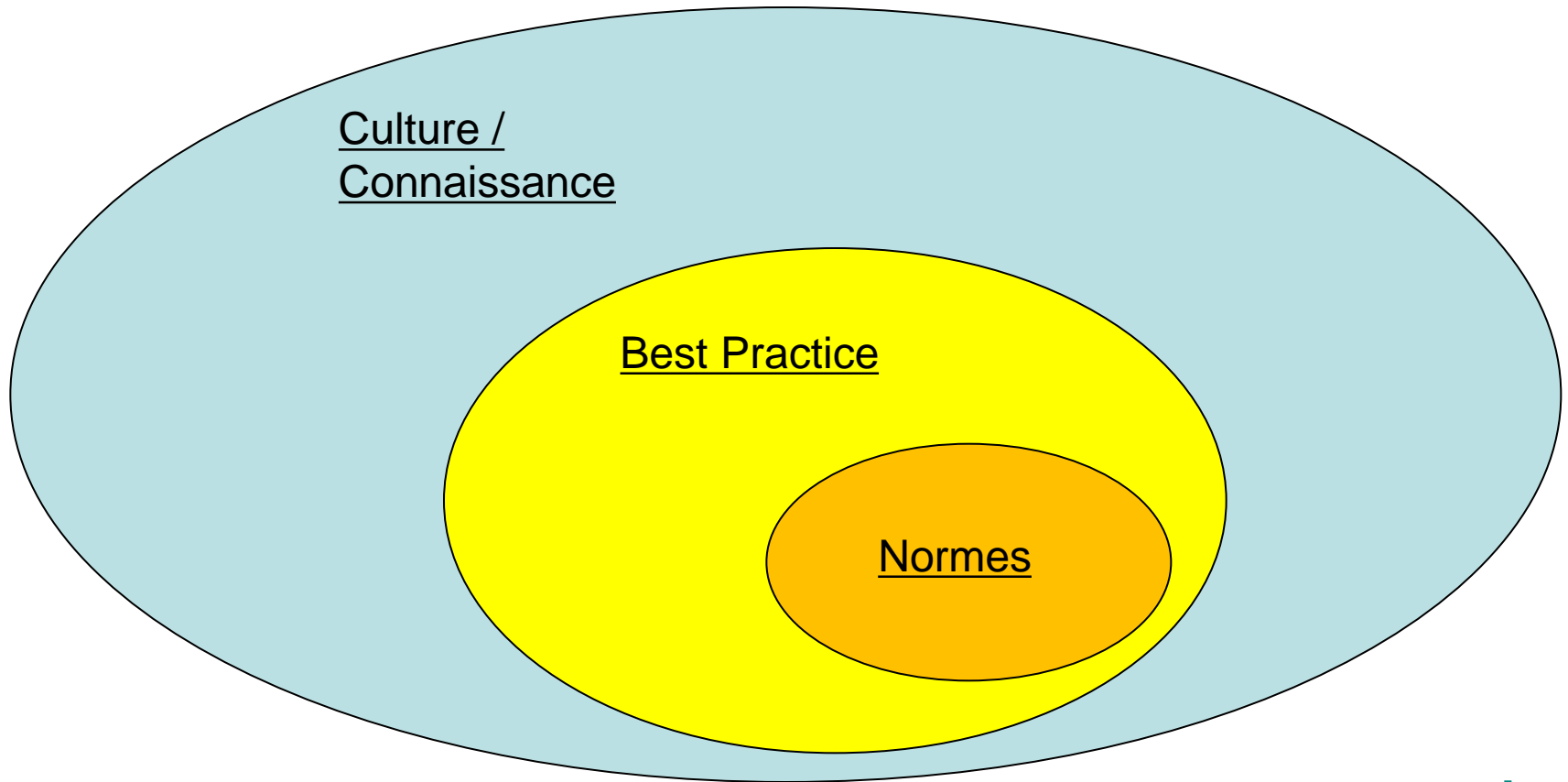



# Les normes

- Bien:
  - Harmonisation
  - Garantie de sûreté des construction
  - Garantie de durabilité des construction
  - Garantie de économicité des construction
- Mal:
  - Quelquefois trop de détails (Eurocode)
  - « Tecnicisme »



# Les normes

- Doit être:
  - Simple
  - Mais efficace



# DICAM

- Depuis début 1900 a contribué a:
  - Création d'une culture pour le dessin économique et fiable des bâtiments
  - Création des norme italiennes (première norme en 1909 Silvio Canevazzi, en 1970 avec Piero Pozzati, en 2005 avec Claudio Ceccoli)
  - Avec un particulier attention a obtenir des normes que soit de même: efficace mais pas trop « restrictive »

# Un premier étape

- **Centre de Recherche sur les Technologies et les Matériaux de Construction du Génie Civil (CRTM)**

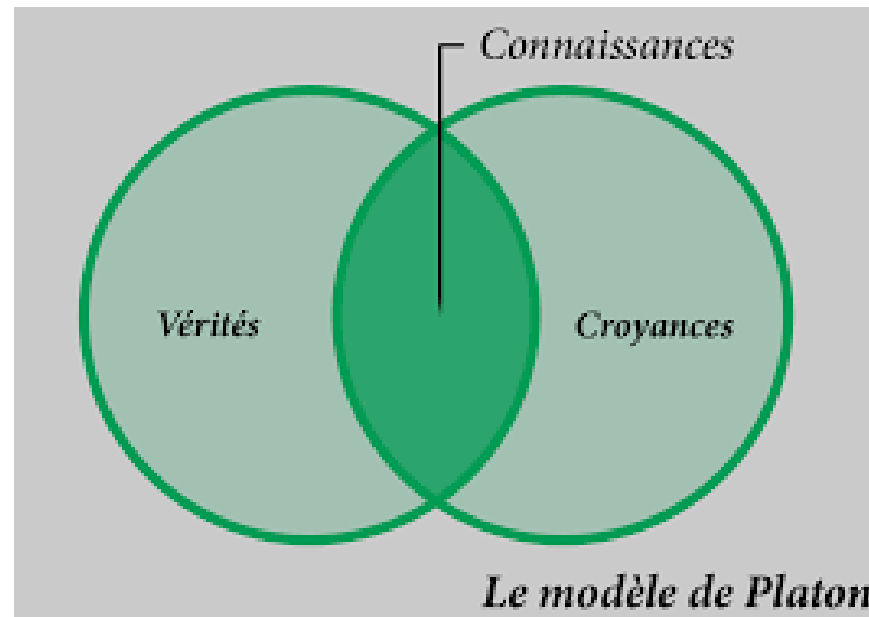



# DICAM

**School:** School of Engineering and Architecture,  
University of Bologna

**Department:** Department of Civil, Chemical, Environmental  
and Materials Engineering - DICAM

**Structures:**

1. Viale del Risorgimento 2, Bologna
2. Via Terracini 28, Bologna





# DICAM



## Human Resources

Professor Francesco Ubertini (Dept Head)  
Professor Fabio Fava (Deputy Dept Head)  
Dr. Lorenza Pucci ( Head of the Dept  
Administration)

<b>Full Professors:</b>	<b>25</b>
<b>Associate Professors:</b>	<b>24</b>
<b>Researchers (Assistant Professors):</b>	<b>40</b>
<b>PhDs:</b>	<b>63</b>
<b>Post Docs:</b>	<b>40</b>
<b>Technical Staff:</b>	<b>22</b>
<b>Administrative Staff:</b>	<b>18</b>

# La r cherche

1. Infrastructures (ponts et chaus e)
2. Batiments et etudes du sol
3. Chimique
4. Materiel et Biotechnologie

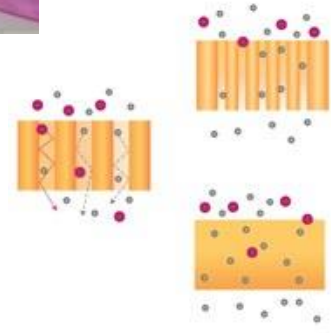
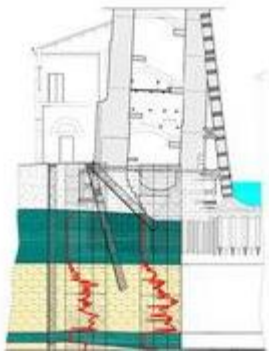
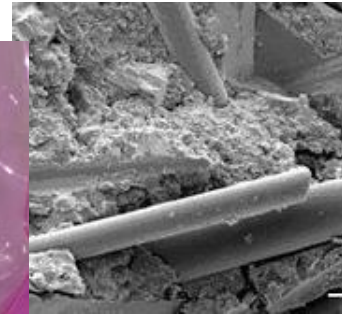



# 1. Infrastructures

- fluid mechanics and hydraulic modeling;
- hydrology, climate processes and water resources management;
- river and torrent hydraulics and landscape preservation;
- maritime hydraulics and coastal engineering;
- water treatment and quality management in the water cycle;
- water distribution and drainage systems;
- analysis of transportation demand ;
- transportation networks analysis;
- materials for road and safety in road infrastructures;
- management and maintenance of road infrastructures;
- geodetic techniques and applications;
- survey techniques for environmental and landscape applications;
- survey techniques for cultural heritage applications;
- applied geology and geomorphology;
- georesources and geoenvironmental modeling;
- excavation engineering and safety;
- LCA, raw material and recycling engineering;
- petroleum, geothermal and underground water engineering;
- rocks and porous media characterization
- engineering technologies for developing countries

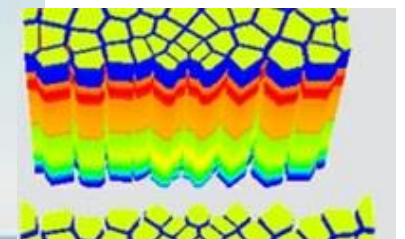
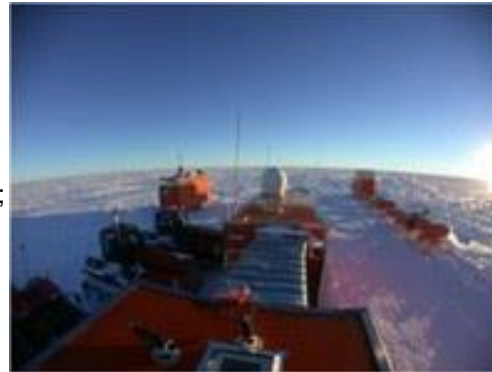

## 2. Batiments

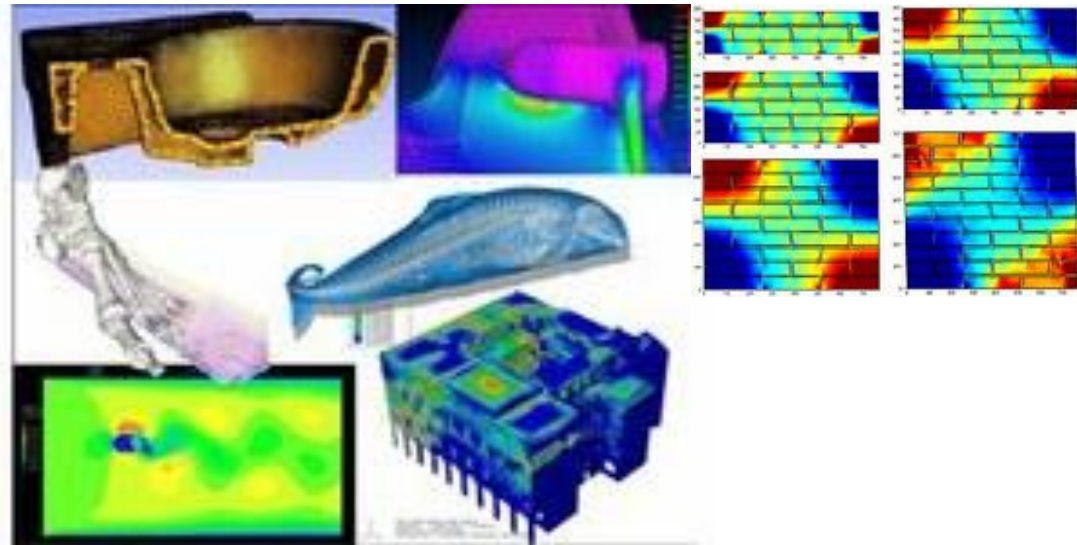

mechanics of solids and structures;  
mechanics of materials, with special attention to new conception materials;  
fracture mechanics;  
computational mechanics;  
theories and techniques for conception and design of safe structures;  
theories and techniques for design and rehabilitation of structures in seismic areas;  
theories and techniques for the intervention on cultural heritage buildings;  
physical and mechanical characterization of soils and rocks;  
constitutive and numerical modeling of geomaterial behaviors;  
behavior modeling of geotechnical works;  
engineering technologies for developing countries

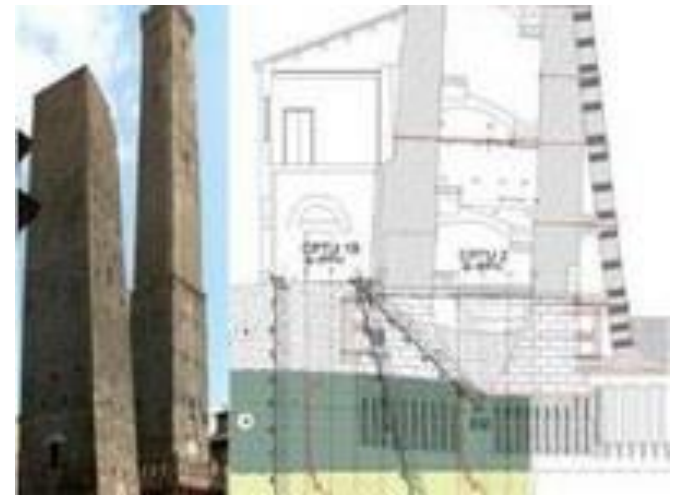

# 3. Chimique

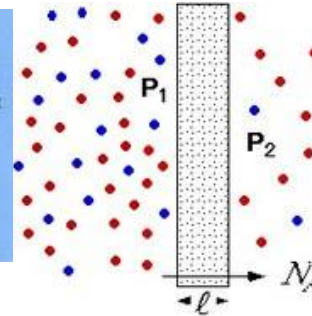
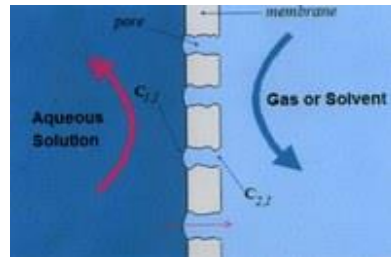
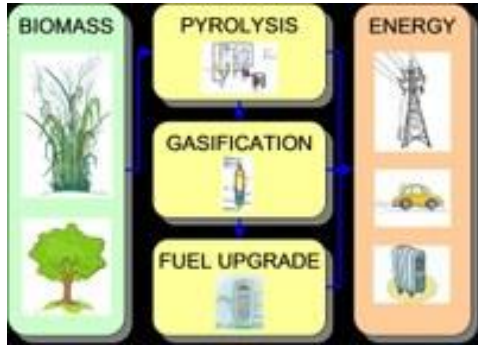

- transport phenomena and Thermodynamics in advanced materials;
- new technologies for environmental protection, energy production and renewable resources management;
- new technologies for biomedical and pharmaceutical applications;
- innovation in chemical and biochemical processes;
- membrane separation processes and membrane reactors;
- bioreactors for environmental protection and for the production of chemicals and biofuels;
- fluid-dynamic characterization and CFD modeling of process equipment;
- process intensification in the chemical industry and in energy production;
- risk assessment of chemical production processes and of hazardous materials transportation;
- safety and sustainability in the process industry;
- engineering technologies for developing countries



# 4. Materièls

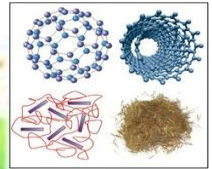
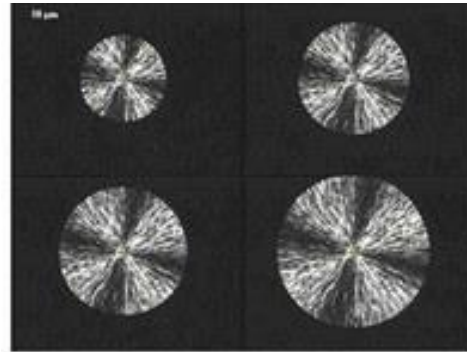

ceramic materials;  
 polymers and composite materials;  
 sustainable materials and durability;  
 materials and technologies for cultural heritage;  
 advanced materials for structural applications;  
 materials for biomedical applications;  
 biopolymers from renewable resources and biodegradable polymers;  
 biocatalysis and biorefinery;  
 food biotechnology;  
 bioremediation;  
 engineering technologies for developing countries



# Laboratories



- **Structural and Geotechnical Engineering**
- Hydraulic Engineering
- Geoenvironmental and Natural Resources
  
- Macromolecular Synthesis and Materials Characterization - LA
- Materials Science and Technology
- Environmental Biotechnologies and Biorefineries
- Chemical Engineering
- Land Surveying and Geomatics
- Computational Mechanics
- Roads
  
- Network



# Laboratoires DICAM





# Laboratoires DICAM



© 2015 Google  
© 2015 Google  
© 2009 GeoBasis-DE/BKG

Google earth



# Laboratoires DICAM





# Laboratoires DICAM





# Laboratoires DICAM



## 2. Batiments

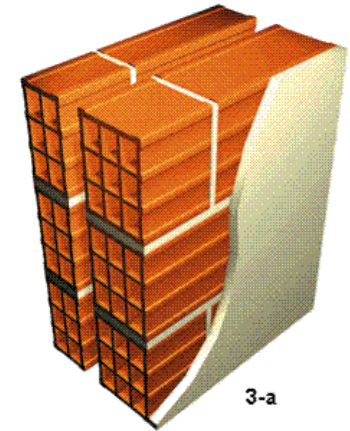
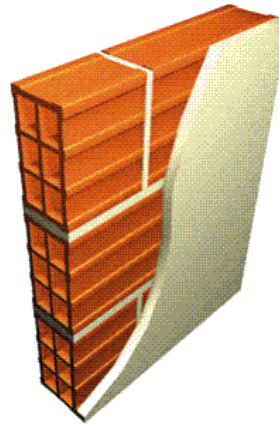
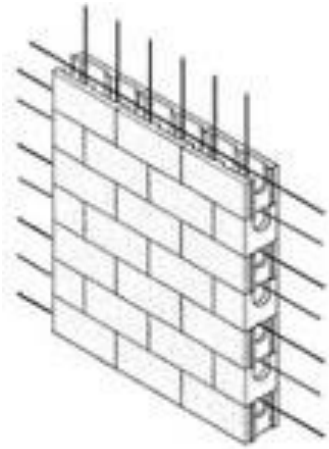

(a)

(b)

(c)

# Construction

## Structures & Material Testing Labs + NDT Lab





# NEW TECHNOLOGIES FOR LOAD BEARING WALLS



[Video](#)

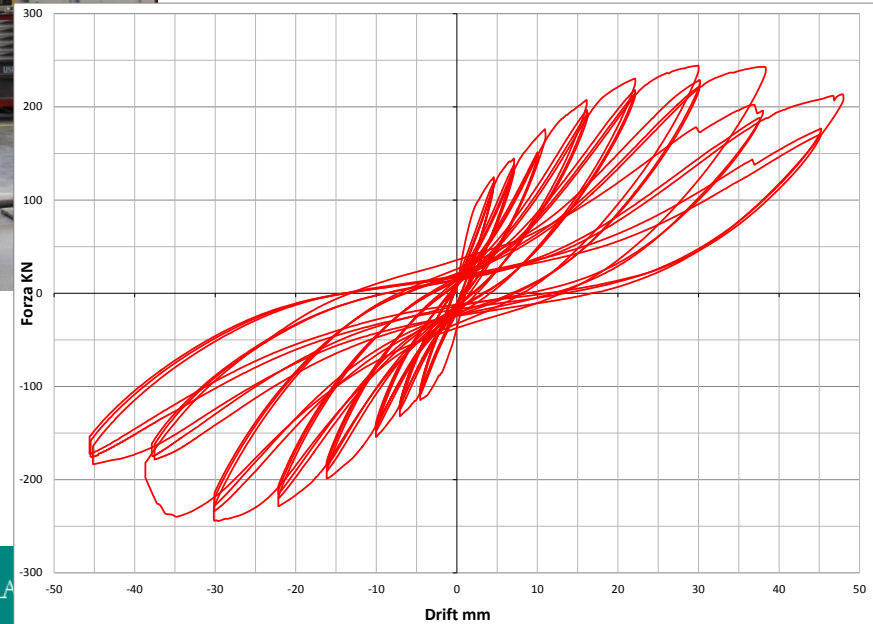

# NEW TECHNOLOGIES FOR LOAD BEARING WALLS

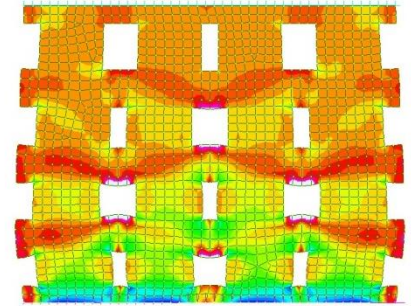

# NEW TECHNOLOGIES FOR LOAD BEARING WALLS

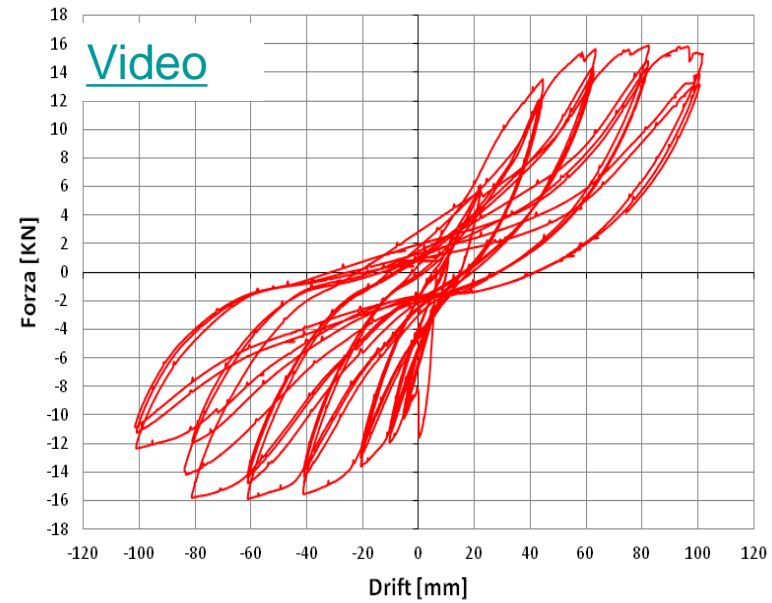

Connection between vertical wall and horizontal slab

# NEW TECHNOLOGIES FOR LOAD BEARING WALLS

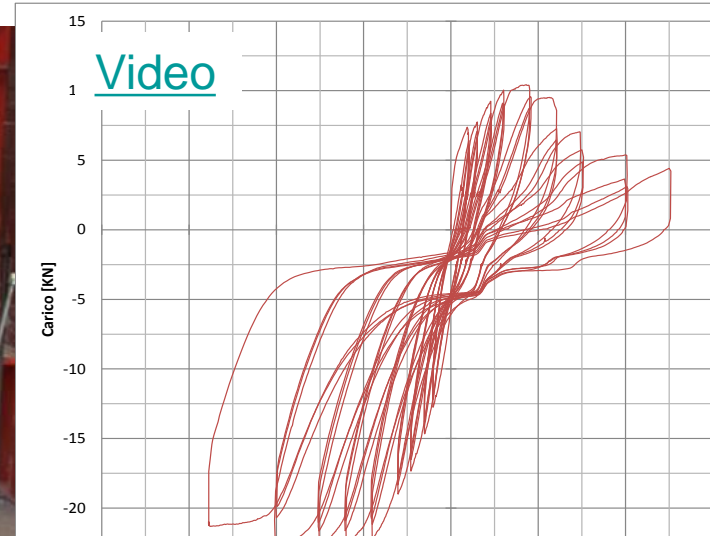
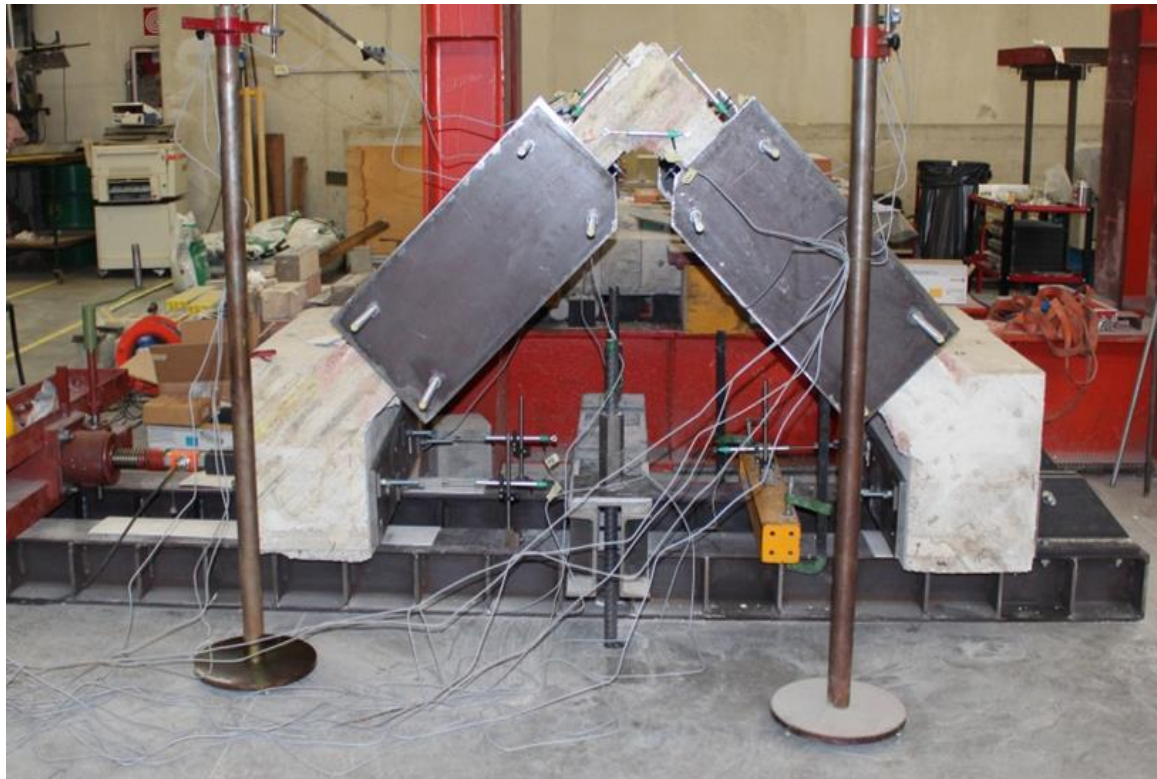

[Video](#)

## Dynamic identification of bridges for high speed railway lines

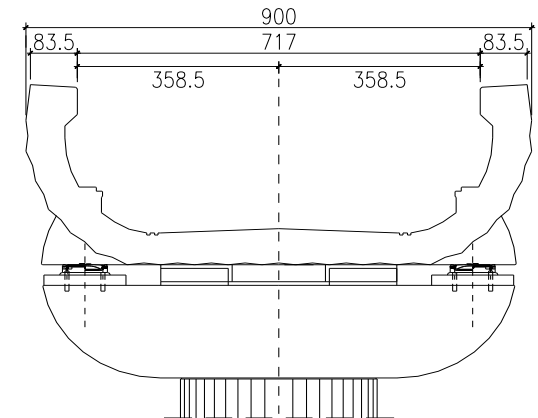
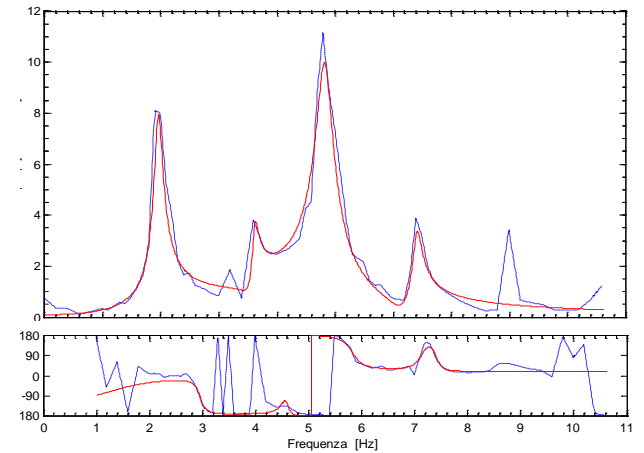

## Tests for the effectiveness of retrofitting systems using innovative materials

Masonry column retrofitted by FRP materials



Masonry wall retrofitted by FRP materials





## Materials Testing Laboratory

NDT testing and monitoring on site

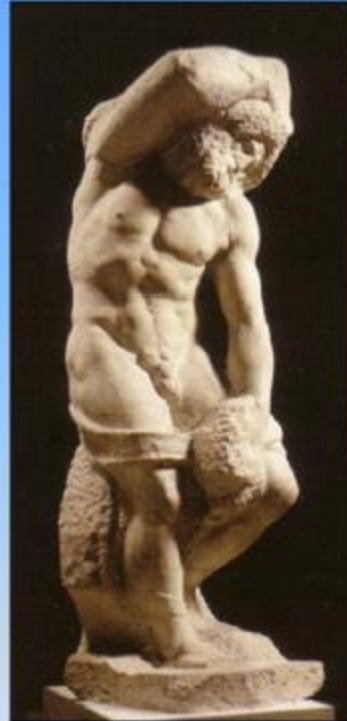

*Contactless monitoring of "movable" CH:  
the "David" and one of the "Prisons" by Michelangelo in  
Florence, experiencing crack problems.*

## Materials Testing Laboratory



*NDT testing and monitoring on site*



*Inspection and testing of historical infrastructures:  
road and railway masonry arch bridges*



# Materials Sciences and Technology

## Self-compacting concrete preparation



**Design of advanced materials with tailored properties**

**Set up of *ad hoc* characterization techniques**



# Materials Sciences and Technology

## Mechanical tests on mortar samples



## Materials Sciences and Technology



**X-rays observations**



**Physical observations**



**Thermal analysis**



**Microstructure analysis**

# Materials Sciences and Technology

## Electrical behaviour, aging and reliability of polymer-based insulating materials

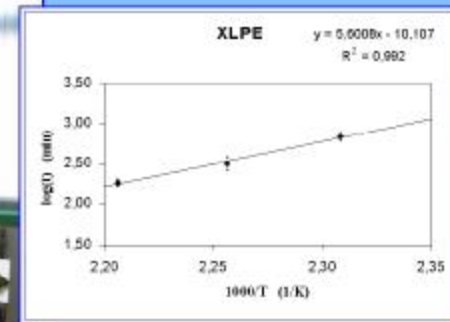
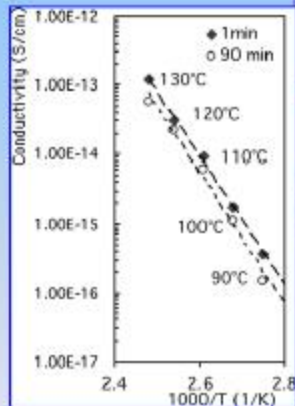

# Computational Mechanical Laboratory

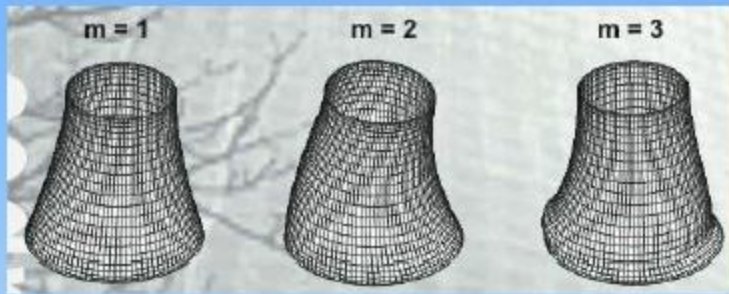

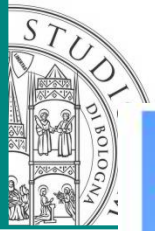

# Transportation Engineering



*Roads & Geotechnique Lab*

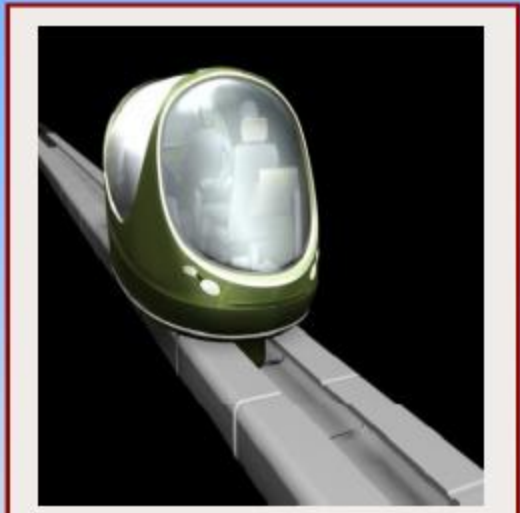

*Transportation Lab*

## Topography Laboratories

Station for creating 3D maps from digital images

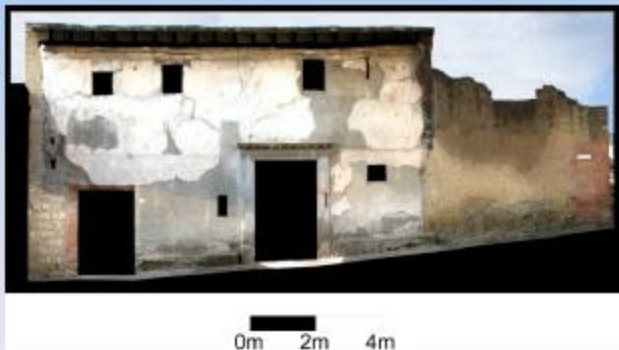
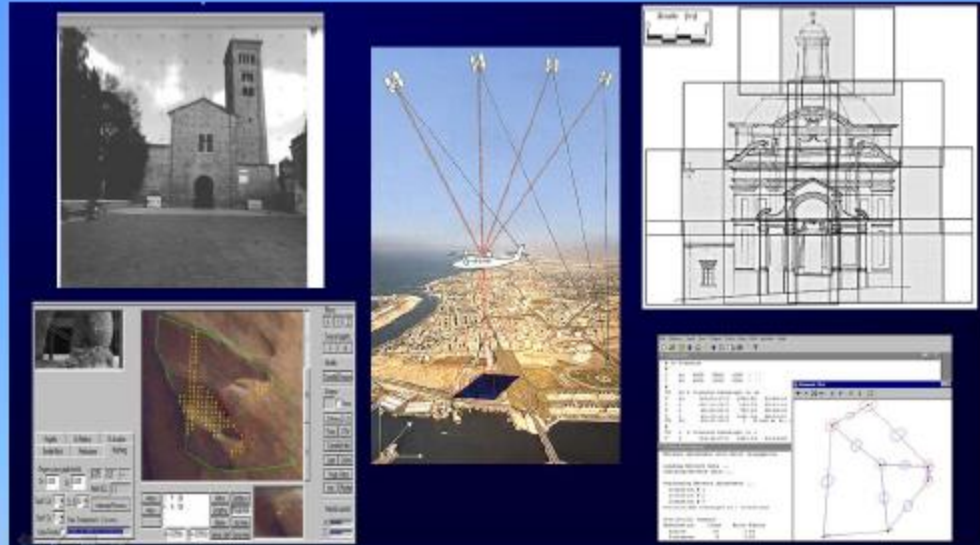

Orthophoto of archaeological construction in Herculaneum

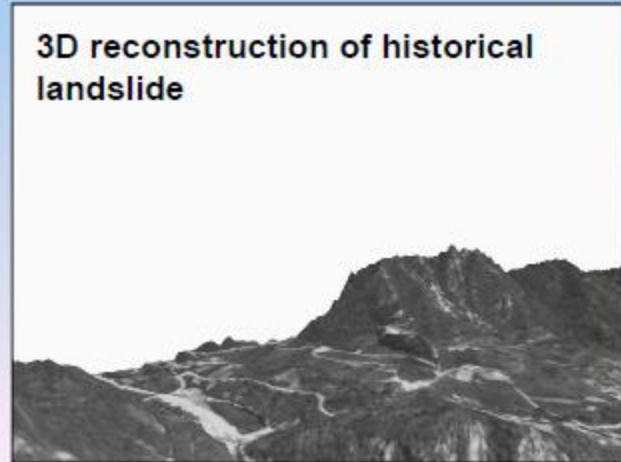

3D reconstruction of historical landslide

**Fluidmechanics  
Hydraulic and Coastal  
Engineering  
Hydrology, Water Resources  
Management, Floods and  
Droughts**



Scale model of bridge on the Reno river (Bologna)



## Geoengineering.

### Excavation and Safety

- Tunnel behaviour under seismic conditions
- Damage caused by shallow tunnelling in urban areas
- Safe excavation in presence of explosive gas
- Design of TBM over 16 m in diameter for gassy



# Laboratories of Environ Biotechnology & Biorefinery

Environmental Biotechnology & Soil/Sediment/Wastewater bioremediation



Biowaste Biorefinery

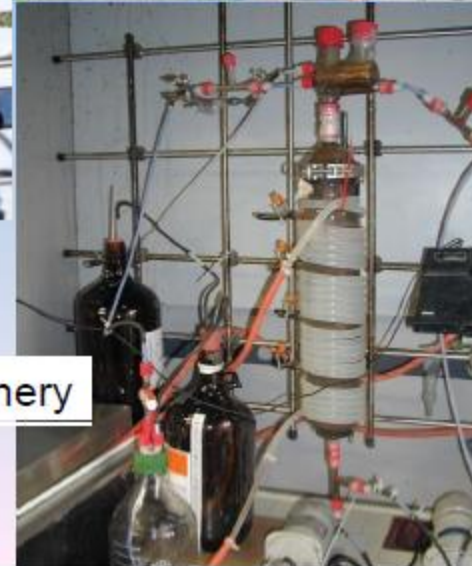



# DICAM

Department of Civil, Chemical,  
Environmental and Materials Engineering

*[www.eng.dicam.unibo.it](http://www.eng.dicam.unibo.it)*